

Rozměrová tabulka skeletů KEUV

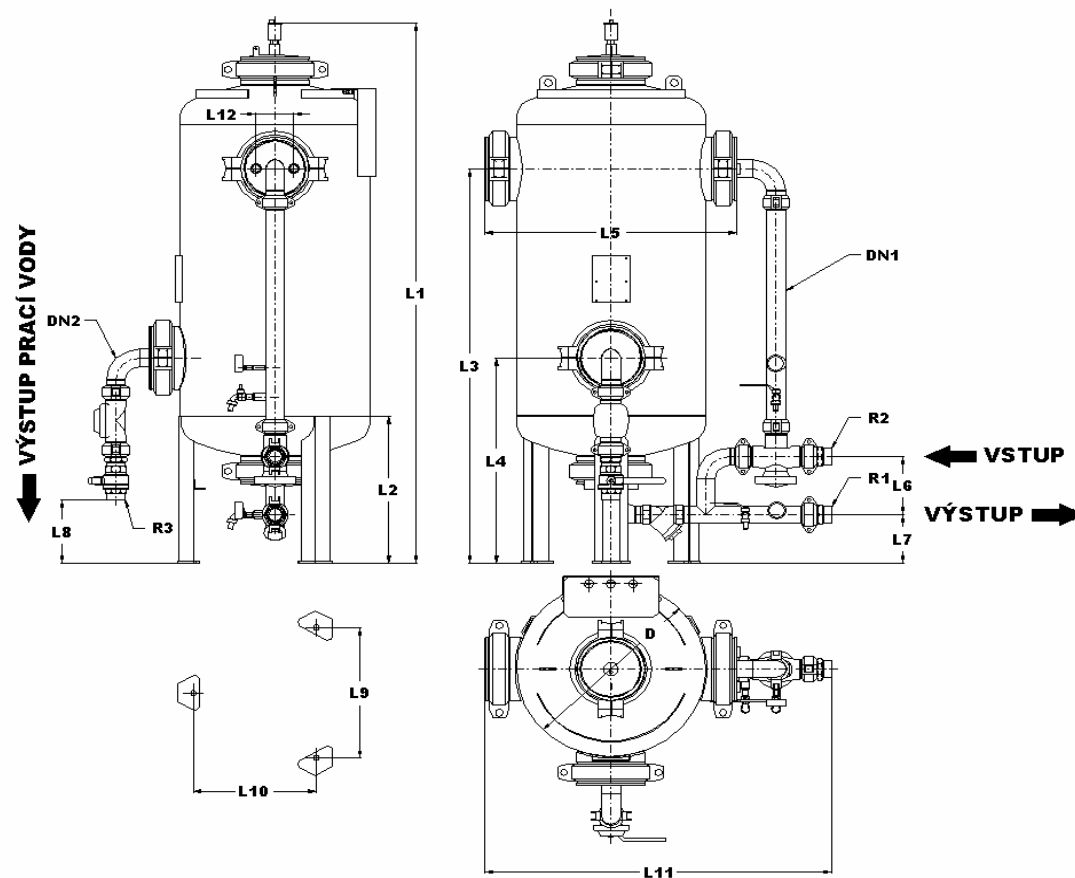

KEUV	D	L1	L2	L3	L4	L5	L6	L7	L8	L9	L10	L11	L12	R1	R2	R3	DN1	DN2
TV MINI	300	1400	375	1043	518	436		100	388	287	206	496	80	R 1 1/2"	R 1 1/2"	R 1 1/2"	40	40
TV 01	400	1613	480	1193	633	536	200	190	145	333	288	1010	80	R 2"	R 2"	R 2"	50	50
TV 02	600	1867	505	1355	705	797	200	166	217	450	388	1010	120	R 2"	R 2"	R 2"	50	50
TV 03	800	2310	732	1730	905	1058	300	305	417	598	518	1510	180	R 3"	R 3"	R 2"	80	50